

编号	修改原因	制图	审核	核准

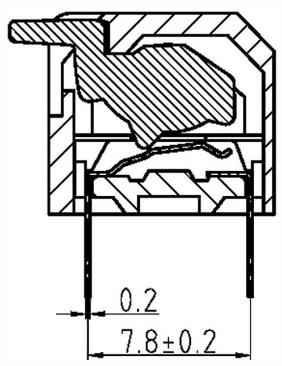
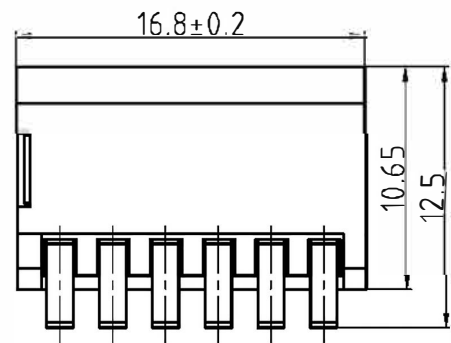

SECTION A-A

SPECIFICATION:

- Rating:  
Switching: 25mA, 24VDC  
Non-Switching: 100mA 50VDC
- Contact Resistance:  
Initial: 50m Ω max  
After Life Test: 100m Ω max
- Insulation Resistance: 100m Ω min/500VDC.
- Withstand Voltage: 500VDC/1min
- Operation Force: 8N max
- Electrical life: 1000 cycles
- Operation Temperature: -25 C ~ +70 C
- Storage Temperature: -40 C ~ +85 C

SOLDERING INFORMATION:

Manual Solering: 30W Iron, 270 C, 2S max  
Wave Soldering: 240 C, 2S max

Keep in "off" position during soldering

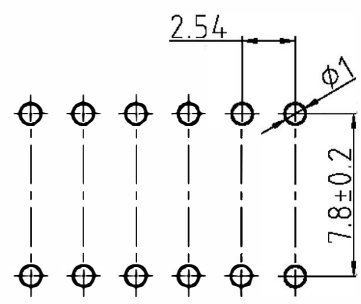
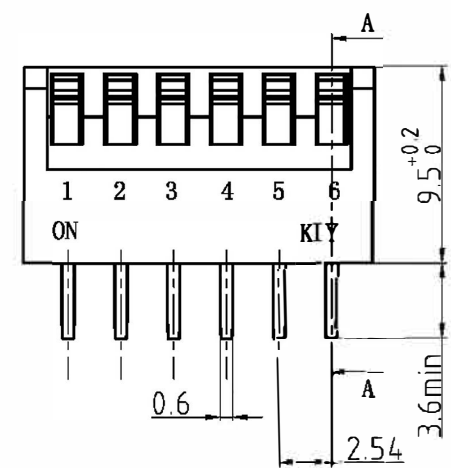

PCB LAYOUT

四 材料

- 盖子: PBT 红色、蓝色
- 底座: PBT 黑色
- 拨键: PBT 白色
- 端子: 磷青铜, 镀金

尺寸公差:	角度公差:	投影法	品名
X. ±0.20	X. ±2°		DP-06
.X ±0.15	.X ±1°	单位	mm
.XX ±0.10	.XX ±0.5°	纸张尺寸	A4
绘图类型	AUTO CAD	产品系列	DP 系列
比例	4:1	图页	1/1
图纸编号	DP-06-AZ01		