

编号	修改原因	制图	审核	核准

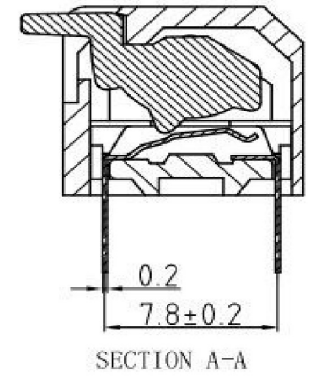

SPECIFICATION:

- Rating:
Switching: 25mA, 24VDC
Non-Switching: 100mA 50VDC
- Contact Resistance:
Initial: 50mΩ max
After Life Test: 100mΩ max
- Insulation Resistance: 100mΩ min/500VDC.
- Withstand Voltage: 500VDC/1min
- Operation Force: 8N max
- Electrical life: 1000 cycles
- Operation Temperature: -25℃ ~ +70℃
- Storage Temperature: -40℃ ~ +85℃

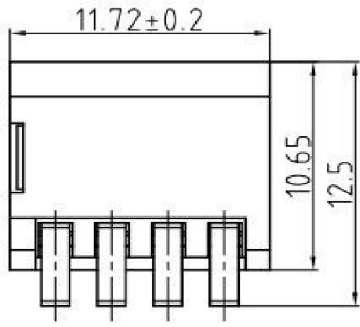
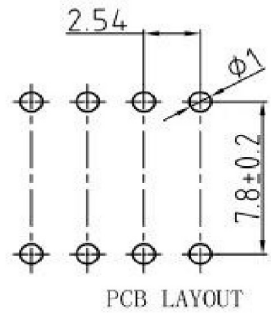
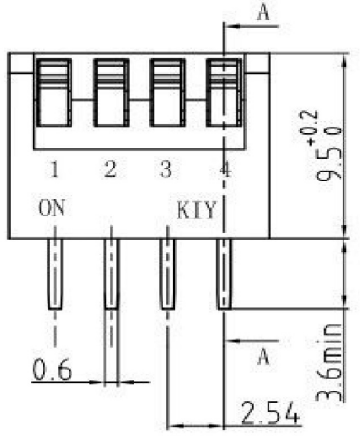

SOLDERING INFORMATION:

Manual Solering: 30W Iron, 270℃, 2S max
Wave Soldering: 240℃, 2S max

Keep in "off" position during soldering

四 材料

- 盖子: PBT 红色、蓝色
- 底座: PBT 黑色
- 拨键: PBT 白色
- 端子: 磷青铜, 镀金

尺寸公差:	角度公差:	投影法		品名	DP-06	
X. ±0.20	X. ±2°	单位	mm	产品系列	DP	系列
.X ±0.15	.X ±1°	纸张尺寸	A4			
.XX ±0.10	.XX ±0.5°					
绘图类型	AUTO CAD					
比例	4:1	图页	1/1			
图纸编号						