

## METAL OXIDE FILM RESISTORS 1/6W-5W

### 1. GENERAL INSTRUCTION :

Type	number	is	described	as	follows:
MOF	1/4W		F(±1%)	I50K	OHM
CLASS	POWER RATING	Tolerance	NOMINAL		Package
			RESISTANCE		
			VALUE		

### 2. NOMINAL RESISTANCE :

The nominal resistance shall be the resistance marked on the resistor body and identified, as a rule, in units,  $\Omega$ ,  $K\Omega$ ,  $M\Omega$ .

### 3. NOMINAL RESISTANCE TOLERANCE .

The nominal resistance tolerance is represented in one capital letter selected from G(±2%), J(±5%), K(±10%), M(±20%).

### 4. RATING :

#### MOF (METAL OXIDE FILM FIXED RESISTORS)

STYLE	MAX WORKING	MAX OVERLOAD	RESISTANCE VALUE RANGE
MOF1/6W / MOF 1/8W	200V	400V	0.1 $\Omega$ ~22M $\Omega$
MOF 1/4W / MOF 1/4WS	300V	600V	0.1 $\Omega$ ~22M $\Omega$
MOF 1/2W / MOF 1/2WS	350V	700V	0.1 $\Omega$ ~22M $\Omega$
MOF 1W / MOF WS	500V	1000V	0.1 $\Omega$ ~22M $\Omega$
MOF 2W / MOF 2WS	500V	1000V	0.1 $\Omega$ ~22M $\Omega$
MOF 3W / MOF 3WS	600V	1000V	0.1 $\Omega$ ~22M $\Omega$
MOF 5W / MOF 5WS	600V	1000V	0.1 $\Omega$ ~22M $\Omega$

#### 4-1. POWER RATING

power rating is defined as maximum power rating continuously applied under ambient temperature at 70°C .when the ambient temperature exceeds 70°C ,use chart 1.

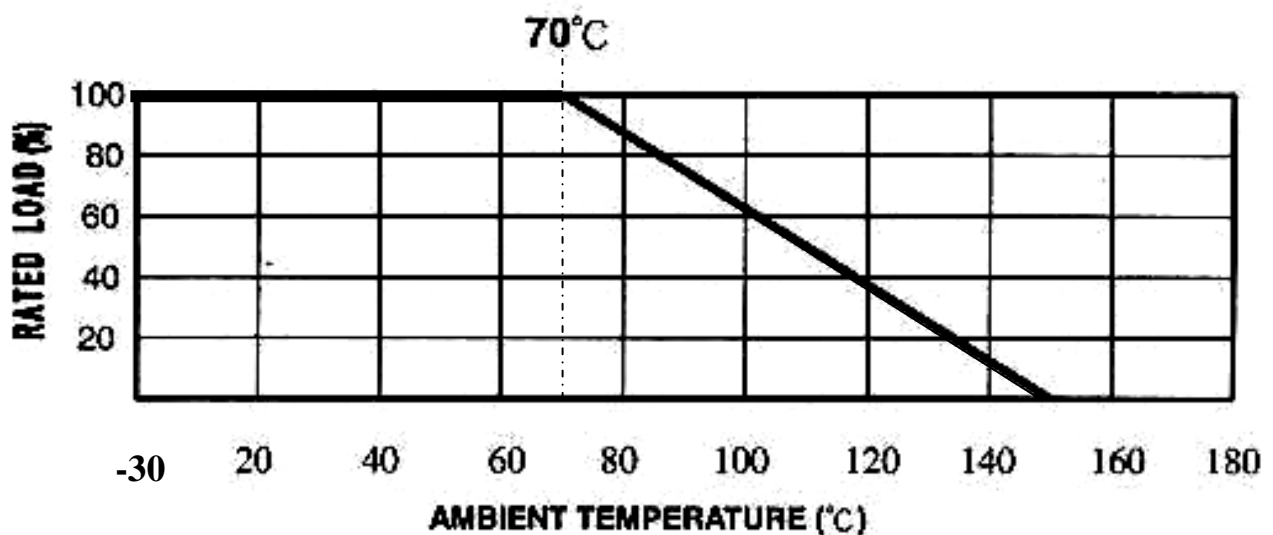

## 4-2. RATED VOLTAGE

Rated voltage is defined as the DC or (AC effective Value at commercial frequency example 50 C/S, 60 C/S)  
 Voltage when rated power is applied and can be calculated  
 By the following EQUATIONE= $\sqrt{P \cdot R}$   
 E=RATED VOLTAGE  
 P=RQTED POWER (WATTS)  
 R=NOMINAL RESISTANCE VALUE (OHM)

When the calculated rated voltage exceeds the Maximum usable voltage flue shown in CHART 1,the Maximum usable voltage is defined as the voltage According to the power-decreasing curve shown in CHART1.

ITEM (STANDARD)	PERFORMANCE AND/OR QUALIITY ACCEPTANCE	TEST METHOD
Resistance value Vs Temperature Characteristics	For $R_x < 100K\Omega$ $+350 \sim -500PPM/^\circ C$ $100K\Omega \leq R_x \leq 1M\Omega$ $0 \sim -700PPM/^\circ C$ $1 M\Omega < R_x$ $0 \sim -1500PPM/^\circ C$	JIS-C-5202 5.2 Measure resistance (Ro ohm) at room Temperature( $T_0 \quad ^\circ C$ ) Measure again the same at $100^\circ C$ Higher than room temperature $PPM = \frac{R - R_0}{R_0} * \frac{10^6}{(T_0+100) - T_0}$
Short time overload	The resistance variation shall be within $\pm(0.75\% + 0.05 \text{ ohm})$ and there Shall be no mechanical breakage	JIS-C-5202 5.5 Apply DC voltage 2.5times the rated Voltage for 5 seconds The leave at room temperature for 30 Minutes then measure MAX overload Voltage 0.50W – 700V (DC)
ITEM (STANDARD)	PERFORMANCE AND/OR QUALIITY ACCEPTANCE	TEST METHOD
Insulation resistance	1000M ohm or more	JIS-C-5202 5.6 In V-BLOCK Lay the resistor on $90^\circ$ angle metal V Block apply 100VDC between resistor Lead and V block for one Minute And Measure
Voltage endurance	The resistance variation shall be within $\pm(2\% + 0.05\text{ohm})$ and there shall be no mechanical breakage	JIS-C-5202 5.7 Icy the resistor on the $90^\circ$ angle metal V Block and apply reamed AC voltage for One Minute. Test voltage 0.25W – 500V (AC) 0.50W – 700V(AC)
Intermittent overload	Resistance variation shall be Within $\pm(2.00\% + 0.05\text{ohm})$	JIS-C-5202 5.8 Apply AC voltage 4 times the rated voltage for 1 second and rest for 25 seconds and Repeat this cycle for 10000 $\pm$ 200times leave resistor 30 minutes at room temperature after test and measure Maximum voltage for intermittent Overload.0.50W-700V(AC)
Terminal strength	Resistance variation shall be within $\pm(0.5\% + 0.05\text{ohm})$ also there Shall be on mechanical breakage	Pull test: apply 2.5kg force to the lead in the direction of lead axislor30 $\pm$ 5 seconds.
Heat resistively Against soldering	Resistance variation shall be within $\pm (1.0\%+0.05\text{ohm})$ also there Shall be on mechanical breakage	JIS-C-5202 7.10 Dip the lead in to a solder bath having a Temperature of $350^\circ C \pm 10^\circ C$ up to $4 \pm 0.8\text{mm}$ from the body of the resistor at room temperature 3 hours after ,then Measure
Solder ability	More than 95% of the surface of the lead shall be covered by new solder after the leads are dipped in the Solder	JIS-C-5202 6.5 Dip the lead in to a solder bath having a Temperature of $260^\circ C \pm 5^\circ C$ up to $4 \pm 0.8\text{mm}$ from the body of the resistor and hold it for $5 \pm 0.5\text{seconds}$ then inspect
Humidity load test	Resistance variation be Within $\pm(3.0\% + 0.05\text{ohm})$ Also there shall be mo mechanical breakage	JIS-C-5202 7.9 In temperature chamber having temperature $40^\circ C \pm 2^\circ C$ , relative humidity 90 – 95%, Apply rated voltage 1.5hour and shut voltage 0.5 hour repeat this cycle for 1000 hours, leave in room temperature for lhour after test, then measure
Load life test	The variation of the resistance Shall be within $\pm (3\%+0.05\text{ohm})$ Also there shall be no mechanical Breakage	JIS-C-5202 7.10 In the constant temperature chamber having Temperature $70^\circ C \pm 2^\circ C$ , apply rated Dc voltage for 1.5hour and shut voltage for 0.5 hour and repeat thin cycle for 1000 hours, leave in room temperature lhour after test, then measure

## 5. Marking

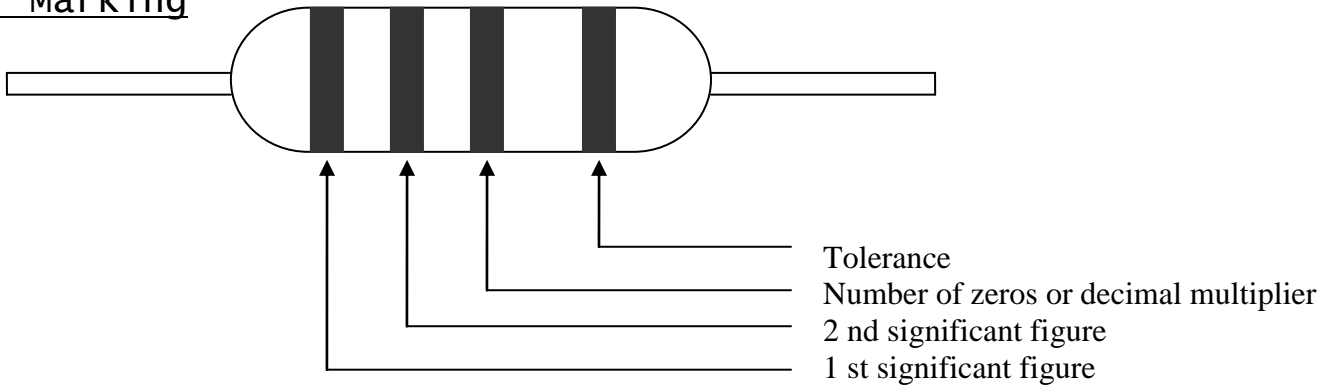

### Color refer

Color	1 st Band	2 nd Band	3 rd Band	4 th Band
Black	0	0	10 <sup>0</sup>	
Brown	1	1	10 <sup>1</sup>	
Red	2	2	10 <sup>2</sup>	±2.0%
Orange	3	3	10 <sup>3</sup>	
Yellow	4	4	10 <sup>4</sup>	
Green	5	5	10 <sup>5</sup>	
Blue	6	6	10 <sup>6</sup>	
Violet	7	7	10 <sup>7</sup>	
Grey	8	8	10 <sup>8</sup>	
White	9	9	10 <sup>9</sup>	
Gold			10 <sup>-1</sup>	±5.0%
Silver			10 <sup>-2</sup>	±10.0%

## 6. Construction and Dimension

### 6-1. Construction

- Tinned Copper Wire .
- Tinned Iron Caps.
- Carbon Film
- Ceramic Rod
- Epoxy Resin.
- Color Code

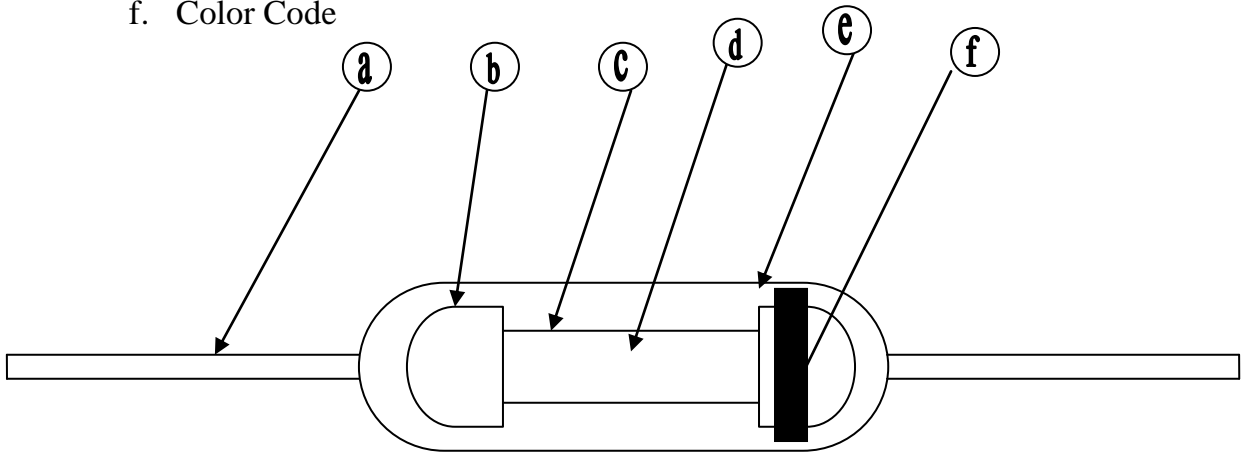

### 6-2 Dimensions

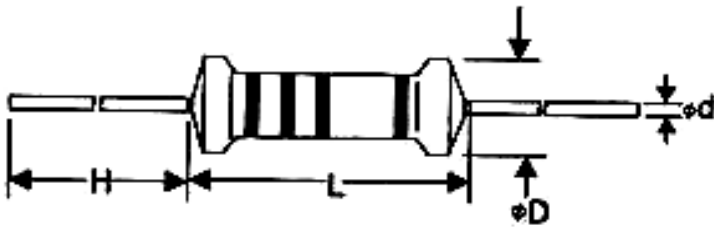
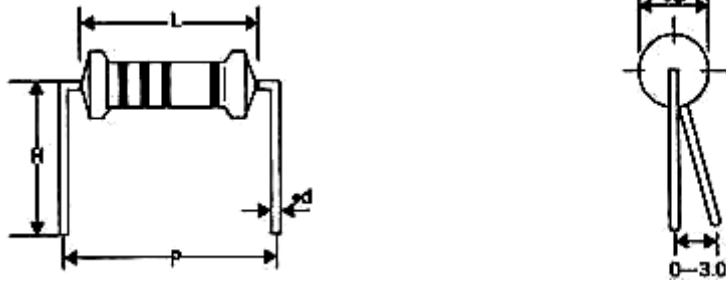

TABLE:

WATTS	L	D	H	d ±0.05mm	PULLING (Kg)
1/6W 1/8W 1/16W	3.3±0.3	1.8±0.3	28±2.0	0.33	2.5Kg - 30S
1/4WS					
1/4W	6.0±0.5	2.3±0.3	27.0±2.0	0.33	2.5Kg - 30S
1/2WS					
1/2W	9.0±0.5	3.0±0.3	26.0±2.0	0.50	2.5Kg - 30S
1WS					
1W	11.0±1.0	3.2±0.5	26.0±4.0	0.50	3Kg - 30S
2WS					
2W	15.0±1.0	5.0±0.5	33.0±2.0	0.50	5Kg - 30S
3WS					
3W	17.0±1.0	6.0±0.5	32.0±2.0	0.60	5Kg - 30S
5WS					
5W	24.0±1.0	8.0±1.0	28.0±2.0	0.70	5Kg - 30S

## 7. FORMED DIMENSIONS

### 7-1. M – TYPE



WATTS	DIMENSIONS (mm)				
	L	P±1.0	D	d±0.05	H±1.0
1/6W/1/8W/1/16W /1/4WS	3.3±0.3	6	1.8±0.3	0.33	6.0
1/4W/1/2WS	6.0±0.5	10	2.3±0.3	0.33	10
1/2W/1WS	9.0±0.5	12.5	3.0±0.3	0.50	10
1W/2WS	11.0±1.0	12	3.2±0.5	0.45	10
2W/3WS	15.0±1.0	20	5.0±0.5	0.50	15.0
3W/5WS	17.0±1.0	23	6.0±0.5	0.60	15.0
5W	24.0±1.0	33	8.0±1.0	0.70	15.0

### 7-2 . MB – TYPE

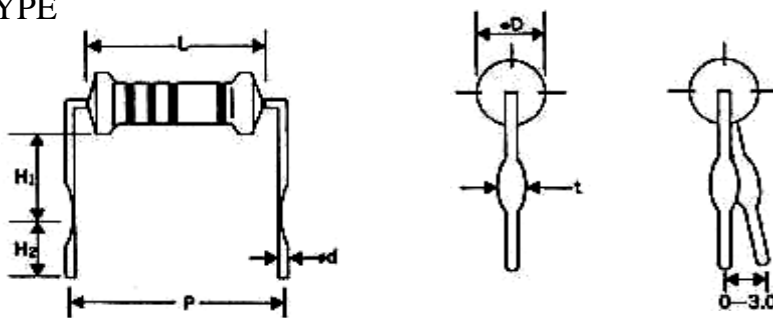

WATTS	DIMENSIONS (mm)						
	L	P±1.0	D	d±0.05	H1±1.0	H2±1.0	t±0.2
1/2W/1WS	9.0±0.5	12.5	3.2±0.3	0.50	6.0	5.0	1.0
1W/2WS	11.0±1.0	15	4.0±0.5	0.60	6.0	5.0	1.3
2W/3WS	15.0±1.0	20	5.0±0.5	0.60	10.0	5.0	1.3
3W/5WS	17.0±1.0	23	6.0±0.5	0.70	10.0	5.0	1.3
5W	24.0±1.0	33	8.0±1.0	0.70	10.0	5.0	1.3

### 7 – 3. F – TYPE

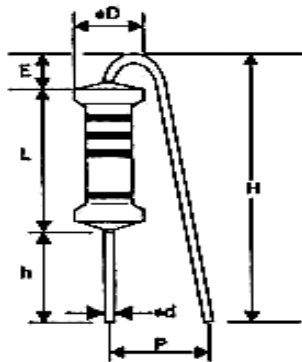

WATTS	DIMENSIONS (mm)						
	L	P±1.0	D	d±0.05	h±1.0	H±1.0	E <sub>max</sub>
1/4W/1/2WS	6.0±0.5	6	2.3±0.3	0.33	5.0	14	3
1/2W/1WS	9.0±0.5	6	3.2±0.3	0.50	5.0	18	3.5
1W/2WS	11.0±1.0	6	4.0±0.5	0.45	5.0	20	3.5
2W/3WS	15.0±1.0	6	5.0±0.5	0.50	5.0	25	3.5
3W/5WS	17.0±1.0	6	6.0±0.5	0.60	5.0	30	3.5

### 7 – 4. FK2-TYPE,FK1 – TYPE AND FKK-TYPE

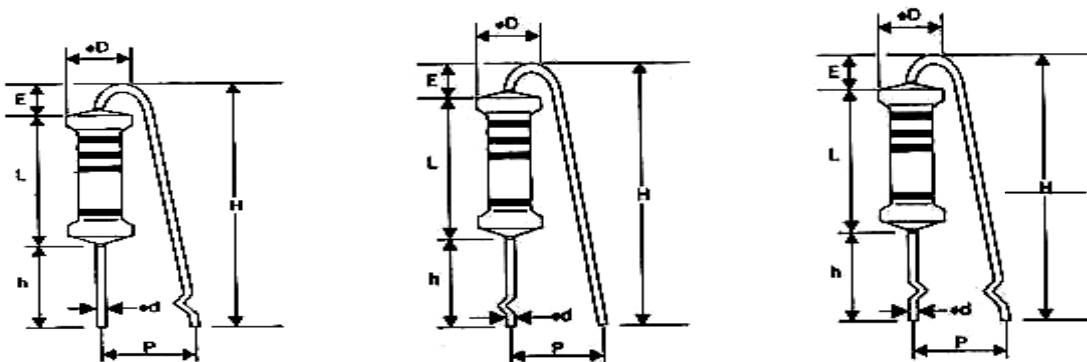

WATTS	DIMENSIONS(mm)						
	L	P±1.0	D	d±0.02	h+1/-0	H±1.0	E <sub>max</sub>
1/2W/1WS	9.0±0.5	6	3.0±0.3	0.50	5	18	3.5
1W/2WS	11.0±1.0	6	3.2±0.5	0.4	5	20	3.5
2W/3WS	15.0±1.0	6	5.0±0.5	0.50	5	25	3.5
3W	17.0±1.0	6	6.0±0.5	0.60	5	30	3.5

## 8. Taping Dimensions

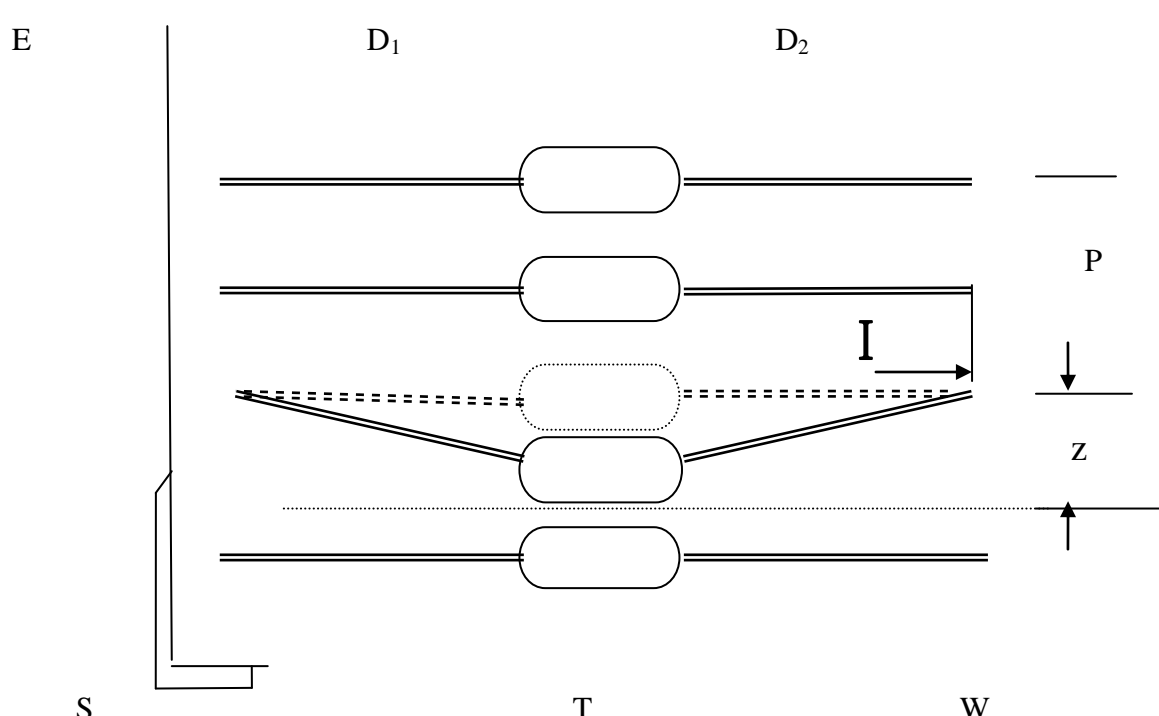

WATTS	Type	T	p±0.5	W±0.5	D1-D2 MAX	E MAX	Z MAX	S MAX	I MAX
1/6W/1/8W 1/16W/1/4WS	T- 26	26±1.5	5	6	0.8	0	1.2	0.8	3.2
	T- 52	52±1.5	5	6	0.8	0	1.2	0.8	3.2
1/4W 1/2WS	T- 26	26±1.5	5	6	0.8	0	1.2	0.8	3.2
	T- 52	52±1.5	5	6	0.8	0	1.2	0.8	3.2
1/2W/1WS	T- 52	52±1.5	5	6	0.8	0	1.2	0.8	3.2
1W/2WS	T- 52	52±1.5	5	6	0.8	0	1.4	0.8	3.2
2W/3WS	T- 73	73±1.5	10	6	0.8	0	1.4	0.8	3.2
3W/5WS	T- 73	73±1.5	10	6	0.8	0	1.4	0.8	3.2
5W	T- 73	73±1.5	10	6	0.8	0	1.4	0.8	3.2

## 9 . PACKING

### 9 - 1. TAPING TYPE

#### LABEL SPECIFICATION

1. TYPE
2. WATTS TOLERANCE
3. RESISTANT QUANTITY
4. P/N
5. LOT NO.

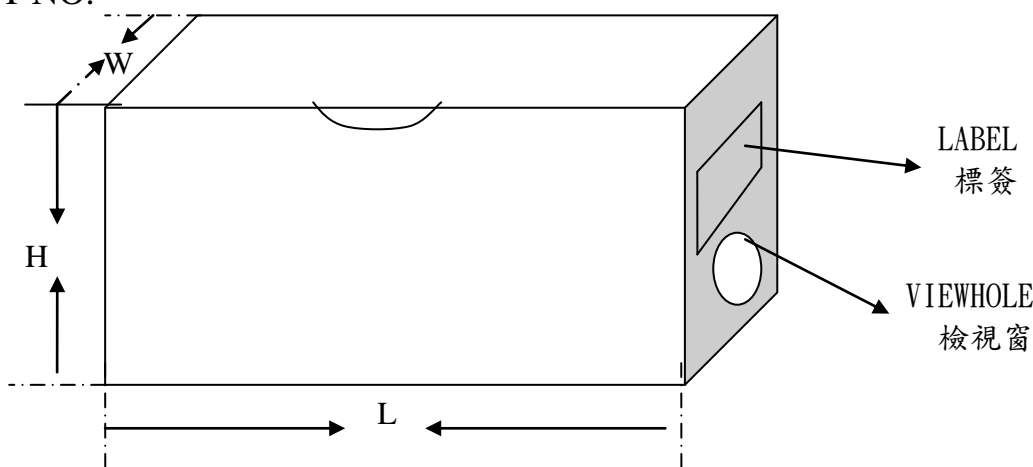

TYPE	WATTS	W(mm)	H(mm)	L(mm)	Q'TY(pcs)
T-26	1/6W 1/8W 1/16W 1/4WS	50	72	260	5000
	1/4W/ 1/2WS	53	103	260	5000
T-52	1/6W / 1/8W 1/16W 1/4WS	73	72	267	5000
	1/4W/ 1/2WS	73	102	267	5000
	1/2W/ 1WS	73	57	255	1000
T-73	1W/ 2WS	92	83	267	1000
	2WS/ 3WS	92	89	267	1000
	3W/5WS	92	83	267	500
	5W	92	83	267	500

### 9-2. BULK

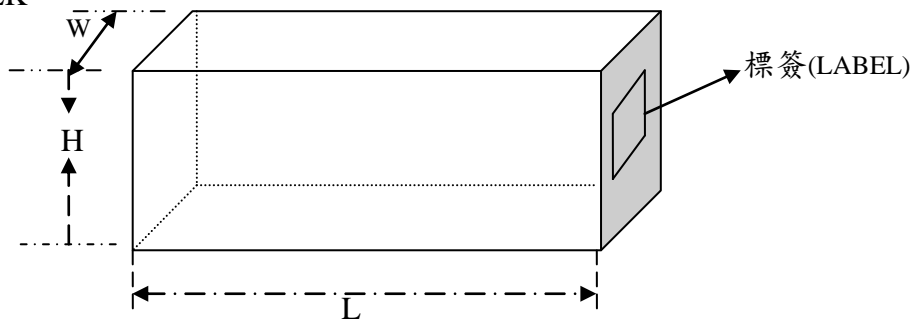

WATTS		TYPE	L(mm)	W(mm)	H(mm)	POLY BOG	BOX(pcs)
1/6W 1/8W	1/16W 1/4WS	P	250	140	67	1000	20000
		MOLDING					
1/4W	1/2WS	P	250	140	67	500	10000
		MOLDING					
1/2W	1WS	P	250	140	67	500	5000
		MOLDING					
1W	2WS	P	250	140	67	200	2000
		MOLDING					
2W	3WS	P	250	140	67	200	1000
		MOLDING					
3W/5WS		P	250	140	67	100	1000
		MOLDING					
5W		P	250	140	67	100	1000
		MOLDING					