

Chengdu Kingbri Frequency Technology Co.,Ltd



Headquarter Add: NO.8 Baiye Road,West District of Chengdu international.High-tech Development Zone,Sichuan,China

Tel: +86-28-66118657 66118658 66118659

Fax: +86-28-66118501

Postcode: 611731

E-mail: sales01@chinacrec.com mar@chinacrec.com crecsz01@chinacrec.com

Website: www.chinacrec.com

Shenzhen Office Add: NO.2907,Block A, Building 1, Nanguang City Garden, Nanguang Road, Nanshan District, Shenzhen, Guangdong

Tel: +86-755-36931821 83475957 33654281

Fax: +86-755-83475977

Postcode: 518048

E-mail: crecsz@chinacrec.com

Website: www.chinacrec.com



CREC QUARTZ CRYSTAL UNITS



SPECIFICATIONS FOR APPROVAL

CUSTOMER: _____ TR011 _____

CUSTOMER P/NO: _____

OUR MODEL NO: _____ HC-49S 3.686400MHz 16pF _____

DESCRIPTION: _____ QUARTZ CRYSTAL HC-49S _____

SPECIFICATIONS NO: _____ CM3.6864F16F3EB _____

SPEC NO: _____

FOR CUSTOMER MODEL: _____

DATE: _____ 2017-02-11 _____

ENGINEERING DEPT: _____ **APPROVED BY CUSTOMER :** _____

Jack Huang **SIGNATUER:** _____

DATE: _____ **DATE:** _____

2017-02-11



Chengdu Kingbri Frequency Technology Co.,Ltd

Headquarter Add: NO.8 Baiye Road, West District of Chengdu international. High-tech Development Zone, Sichuan, China

Tel: +86-28-66118657 6618658 66118659

Fax: +86-28-66118501

Postcode: 611731

E-mail: sales01@chinacrec.com mar@chinacrec.com crecsz01@chinacrec.com

Website: www.chinacrec.com



CREC QUARTZ CRYSTAL UNITS



SPECIFICATION

Client Name: TR011
 Product : Quartz Crystal Resonator
 General Part Number and Client Part Number:
 General :
 Client :

Manufacturer:
 Chengdu Kingbri Frequency Technology Co.,Ltd
 NO.8 BaiyeRoad,West District of Chengdu international High-tech Development Zone,Sichuan,China.
 Post Code: 611731
 TEL +86-28-66118657 66118658 66118659/ FAX +86-28-66118501

Prepared	Checked	Approved
<i>Liu Haiyan</i>	<i>Li Chunyan</i>	<i>Jack Huang</i>

Remarks:
 Product Liability, Quality Assurance and Right of the patent shall be under the responsibility of the Manufacturer mentioned above.

Client Acknowledgement:

Date of receipt :



CREC QUARTZ CRYSTAL UNITS

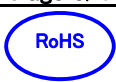

Record of Change

	Issuing Date	Last	New	Page	Contents of the Change	Reason	Remarks
		Version	Version	Item#			
1							
2							
3							
4							
5							
6							
7							
8							
9							
10							



CREC QUARTZ CRYSTAL UNITS



APPROVAL SHEET

SCOPE:

THIS SPECIFICATION SHOULD BE APPLIED TO CRYSTAL RESONATOR, WHICH BE

DELIVERED TO TR011

CUSTOMER:

TR011

CREC PART NUMBER:

C - M - 3.6864 - F - 16 - F - 3 - E - B

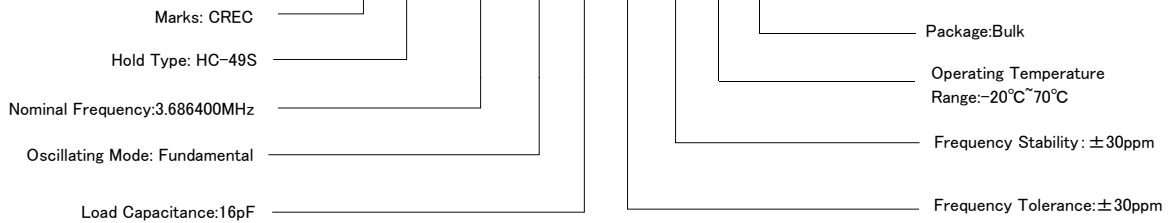

PART TYPE :

QUARTZ CRYSTAL (HC-49S)



CREC QUARTZ CRYSTAL UNITS

SPECIFICATION OF QUARTZ CRYSTAL UNITS

1.HOLDER TYPE:HC-49S

2.GENERAL

2-1 FREQUENCY (F0)	3.686400MHz
2-2 MODE OF OSCILLATION (Mn)	FUNDAMENTAL(AT)
2-3 OPERATION TEMPERATURE RANGE (T0)	-20°C~70°C
2-4 STORAGE TEMPERATURE RANGE (Ts)	-40°C~+85°C
2-5 TEST SET	S&A 250B Network Analyzer
2-6 DRIVE LEVEL (DL)	100 μ W/Max
2-7 LOADING CAPACITANCE (CL)	16pF

3.ELECTRICAL CHARACTERISTICS

3-1 FREQUENCY TOLERANCE (Δf)	$\pm 30\text{ppm/Max at } 25 \pm 2^\circ\text{C}$
3-2 EQUIVALENT RESISTANCE (Rr)	150 Ω /Series
3-3 TEMPERATURE DRIFT (Tc)	$\pm 30\text{ppm/ Max } -20^\circ\text{C} \sim 70^\circ\text{C}$
3-4 SHUNT CAPACITANCE (Co)	7.0pF/Max
3-5 MOTIONAL CAPACITANCE(C1)	N/A
3-6 INSULATION RESISTANCE	500M Ω min/DC100V $\pm 15\text{V}$ (Lead to lead ,case to lead)
3-7 AGING RATE PER YEAR:	$\pm 5\text{ppm/Year}$

4.DIMENSIONS AND MARKING

4-1 HOLDER TYPE AND DIMENSION (mm)

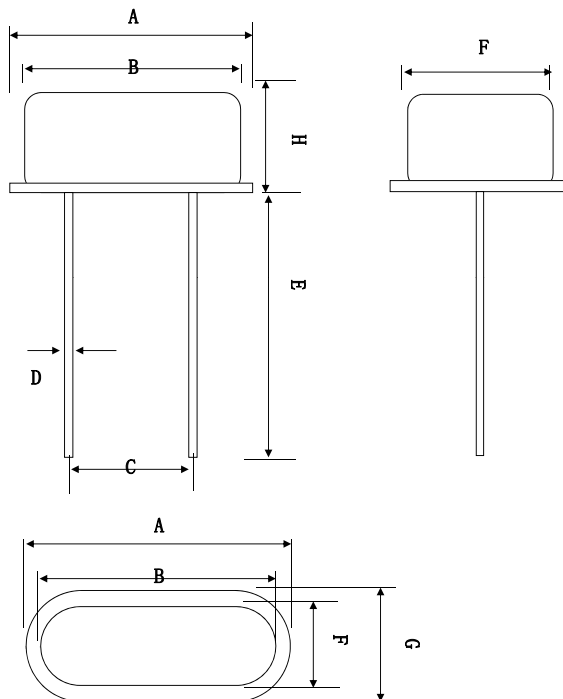

A	11.50MAX
B	10.30MAX
C	4.88 \pm 0.2
D	0.45 \pm 0.05
E	13.2 \pm 0.5mm
F	3.80MAX
G	4.70MAX
H	3.68MAX



4-2 MARKING

CREC3.6864

4-3 Crystal Test circuit (TEST SET S&A 250B) :

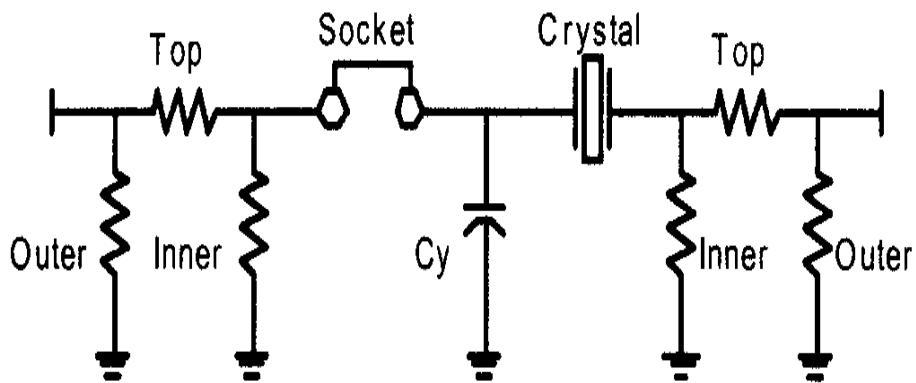

LNA 12.5 Ohm PI

PI Outer Resistor=159.0

PI Top Resistor=66.2

PI Inner Resistor=14.2



CREC QUARTZ CRYSTAL UNITS

RoHS

4-4 PACKING FOR APPROVAL

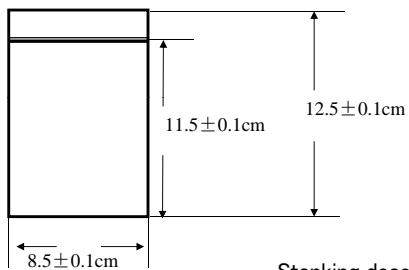
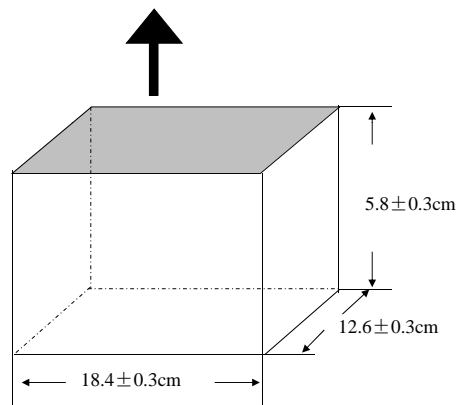
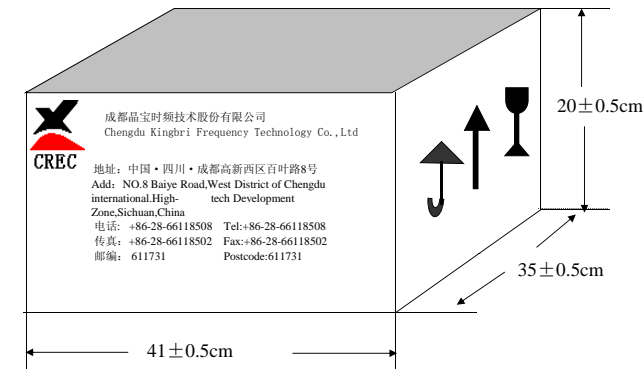

Stanking description:

①HC-49U:

100pcs crystal units in 1 small packet, 10 small packets in 1 box, 10 boxes in 1 big box, (10000pcs crystal units in 1 big box)

②HC-49S:

200pcs crystal units in 1 small packet, 10 small packets in 1 box, 10 boxes in 1 big box, (20000pcs crystal units in 1 big box) .

③Φ3× 9、Φ3× 8、Φ2× 6:

500pcs crystal units in 1 small bag, 10 small bags in 1 box, 10 boxes in 1 big box, (50000pcs crystal units in 1 big box).



5.MECHANICAL ENDURANCE

Provided that measurement shall be carried out after letting it alone in the room temperature for 1 hour.

5-1.SHOCK

Electrical characteristics shall be satisfied after dropping three times from the height of 75cm onto the Concrete.

5-2.VIBRATION

Electrical characteristics shall be satisfied after supplying following vibration.

a).ENTIRE FREQUENCY RANGE	10~2000Hz
b).REPEATED PERIOD	1~2min
c).AMPLITUDE	1.52mm
d).DIRECTION	X.Y.Z
e).ACCELERATED SPEED	20g
f).PERIOD	4hours/Each Direction

5-3.STRENGTH OF TERMINALS/LEAD-WIRES

①TENSILE

- Body of specimen shall be fixed,and 900g of tension weight shall be supplied gradually to axial direction of terminals/lead-wires for 30 sec.
- After above test a),there is no distinct damage or damage to sealing.

②BENDING

- Body of specimen shall be fixed,and 90 degree bending shall be given,being supplied 225g tension weight.After that,terminals/lead-wires shall be straightened gradually. Then the same bending and straightening shall be supplied to the opposite direction in the same axial.
- After above test a),there is no observation of any visual damages on the specimen.

5-4.SEALING TIGHTNESS

Put the specimens in C₂H₅OH,rasie pressure it with 0.5Mpa for 10 min,
test the insulation resistance at DC.100V,the result shall be over 500MΩ.
Electrical characteristics shall be satisfied and no sealing damage.



5-5.SOLDERING HEAT RESISTANCE

Electrical characteristics shall be satisfied .Without distinct looseness of terminals.

①.FLOW Soldering

实测基板温度

(℃)

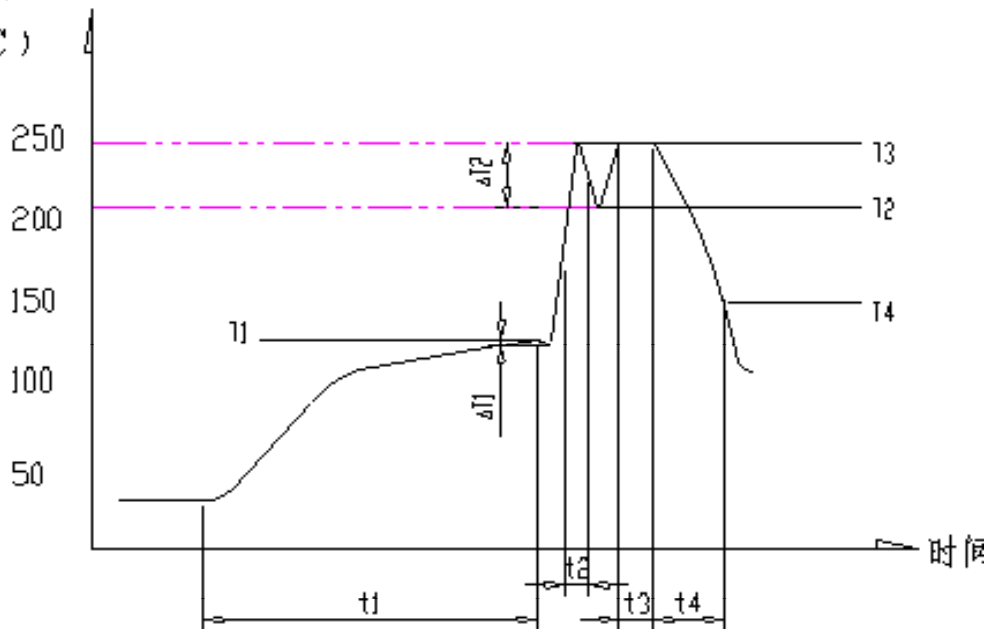

Preheating Time $t_1=60s$

Transmitting Speed at 1.2M/min

Length of Preheating at Least 1.2M

Time of tin-dipping $t_2+t_3=3\sim 5S$

Cooling time $t_4=120S$

②.SOLDERING DIP

Terminals/lead-wires of specimen shall be dipped into solder melter tank at $+245^{\circ}\text{C}\pm 5^{\circ}\text{C}$ for 5 ± 0.5 sec.

Dipping depth shall be 2mm from the bottom of specimens body.(After applying ROSIN FLUX) soldering portion shall be covered in over 95% of Terminals/lead-wires dipped.

③.SOLDER HEATING

Terminals/lead-wires of specimen shall be dipped into solder melter tank at $+260^{\circ}\text{C}\pm 5^{\circ}\text{C}$ for 10 ± 1 sec.

Electrical characteristics shall be satisfied after dipping depth shall be 2mm from edge of terminals/lead-wires.



5-6. ENVIRONMENTAL ENDURANCE

Provided that measurement shall be carried out after letting it alone in the room temperature for 1 hour.

① HUMIDITY

Electrical characteristics shall be satisfied after letting it alone at $60 \pm 2^\circ\text{C}$ in humidity of 95% for 500 hours.

② STORAGE IN LOW TEMPERATURE

Electrical characteristics shall be satisfied after letting it alone at $-40 \pm 3^\circ\text{C}$ for 168 hours.

③ STORAGE IN HIGH TEMPERATURE

Electrical characteristics shall be satisfied after letting it alone at $125 \pm 2^\circ\text{C}$ for 168 hours.

④ TEMPERATURE CYCLE

Electrical characteristics shall be satisfied after supplying the following temperature cycle (3 cycle). Temperature shift from low to high, high to low shall be done in $1^\circ\text{C}/\text{sec}$.

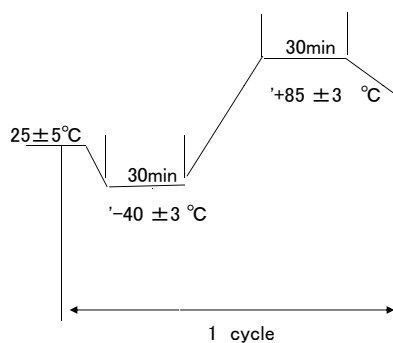



CREC QUARTZ CRYSTAL UNITS

RoHS

6. INSIDE STRUCTURE

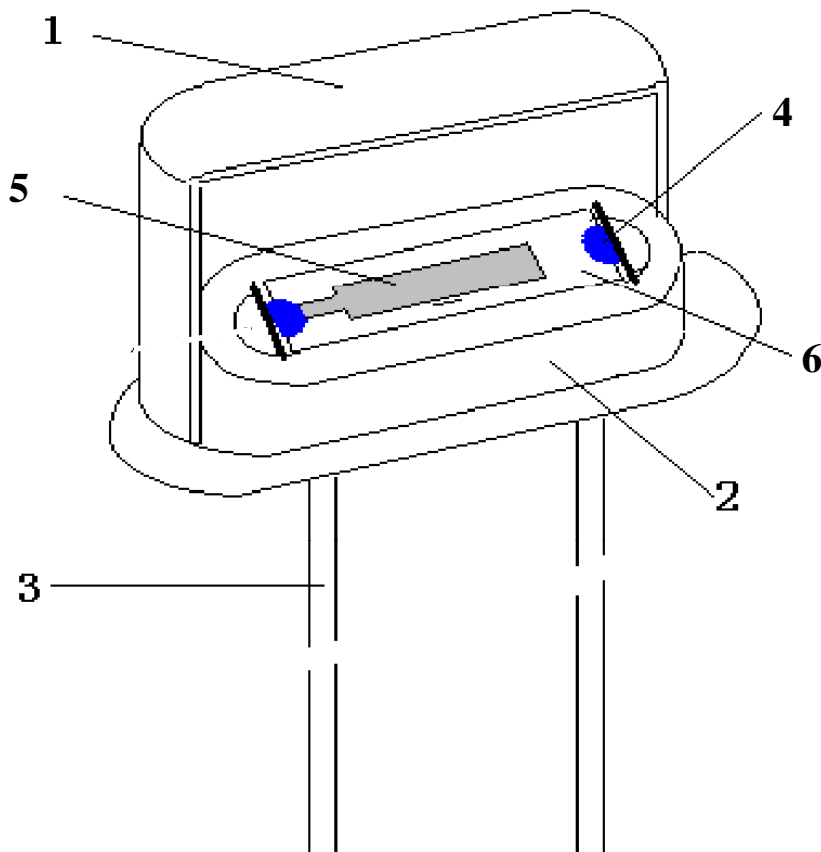

No.	Items	Materials
1	Metal Can	Ni Alloy
2	Substrate	Fe Alloy
3	External Electrode	Kovar (Pb free)
4	Conductive Adhesive	Ag+Epoxy Resin
5	Internal Electrode	Ag
6	BLANK	PZT

Country of Origin: China

Factory Name & Location:

Chengdu Kingbri Frequency Technology Co.,Ltd

NO.8 Baiye Road,West District of Chengdu international.

High-tech Development Zone,Sichuan,China

Tel: +86-28-66118657 66118658 66118659

Fax: +86-28-66118501

Confirmation of Advanced notice of significant change

Messrs. TR011

Advanced notice of any significant alteration

We confirm here that in any case of the following alteration, you will have our written pre-notification and we will not put them into practice unless otherwise we receive your acceptance of the alteration.

- 1.Any change of the contents of the agreed specification of the goods
- 2.Any change of anything not mentioned in the specification but deeply related with the quality, performance and/or reliability of the goods.
- 3.Change of materials and/or its supplier of the goods
- 4.Change of the factory and/or sub-contracted factory of the goods
- 5.Any major change of production procedure of the goods including renewal of production machines.

Feb.11, 2017

Jack Huang

Authorized Signature

Chengdu Kingbri Frequency Technology Co.,Ltd